

Front bumpers FIAT X19 conversion late model to euro-style bumpers early model by Riccardo Borja

It will use exhaust pipe 1 3/4 cutting a little longer than 8 1/4, It can be 9 inches, to cut to the correct size and to keep the exact angle.

This size is exactly the same thing that the bracket of x 1/9 on diameter and length

Use regular motor oil to insert the exhaust pipe, rubbing a couple of drops around, You will insert several times on this process and it will be easy to put and to take out.

step 1:

Put the exhaust pipe in the location of the bracket, use a ruler and mark the angle in the way of the car, Make a mark that indicates the position of the tube (TOP), pull out and cut the exhaust pipe, sand with sandpaper.

step 2:

After fold the iron strip B as shown on the drawing weld to the iron strip A, now you have a part named iron stripAB.

Make the holes on the iron stripAB, it should be aligned with the bumper, screw to the bumper, pull in the exhaust pipe following the marks that indicate the right position, make the marks to the center of the iron strip, pull out the exhaust pipe, unscrew the iron stripAB and to weld. Use bondo to cover the holes between iron strip and exhaust pipe.

step 3:

screw the new bracket to the bumper and install in their place, if it is long cut the other tip of the tube, sand it and verify again, align, mark on the body and make a hole in the correct place.

Fig 4:

introduce the bumper again, screw everything. Inside the trunk where you unscrew the original shock bracket, you will make a mark to make a hole that crosses the new bracket, you will need to take out the bumper again, make the hole, and paint with anti-corrosive paint. screw the bumper and the bracket and put some drops of oil to lubricate and introduce. Put all the screws tight.

You can start with the next bumper of the other side

If it is not well aligned, press or pull with some force to get to the correct alignment or to make bigger holes in the iron strip to correct the problem.

Front bumpers FIAT X19 conversion late model to euro-style bumpers early model by Riccardo Borja

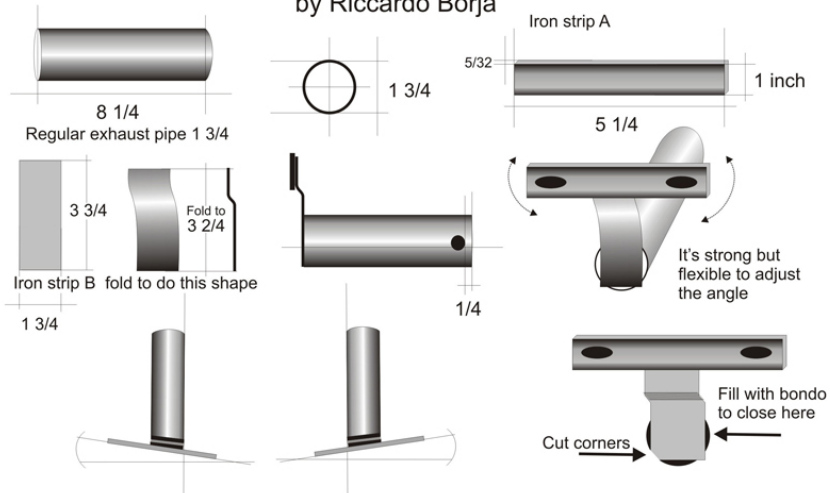

Step 1

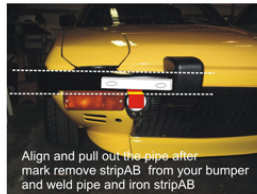

Step 2

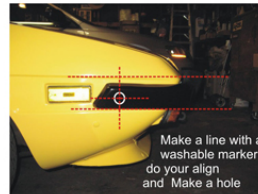

Step 3



Step 4

